

ZYPHO STANDARD

INSTALLATION MANUAL



Please read the entire manual before
starting the installation process.



ÍNDEX

PRODUCT Pag.1

IMPORTANT Pag.1

INSTALLATION Pag.2

INSTALLATION CONFIGURATION Pag.3

TECHNICAL SPECIFICATIONS Pag.3

PACKAGE CONTENTS Pag.4

DIMENSIONS Pag.4

SAFETY Pag.5

MAINTENANCE Pag.5

WARRANTY Pag.6

CONTACTS Pag.6

PRODUCT

ZYPHO is a heat exchanging unit that will allow you to recover the heat contained in the shower waste water and to transfer this heat to the cold water before it goes to the shower mixer tap and/or water heater device. There is no contact between the water supply and the drain water. The transfer of heat is achieved through a double-walled copper coil heat exchanger in accordance with the regulations **EN 1717**. When utilizing the ZYPHO Standard, the cold water feeding into your mixer valve or heater device is pre-heated to approximately 20 - 25°C, an increase of approximately 15°C (depending on the type of configuration and flow of the shower), the result is a significant energy saving.



IMPORTANT!

- The ZYPHO should only be installed by a competent professional who has the expertise to be guided by this manual.
- Please read the entire manual before starting the installation process. Should you have any technical questions don't hesitate to contact us.
- Non-compliance with the recommendations for installation and use may void any warranty.
- Keep this manual in a safe place for easy reference when required throughout the life of the product.

INSTALLATION INSTRUCTIONS

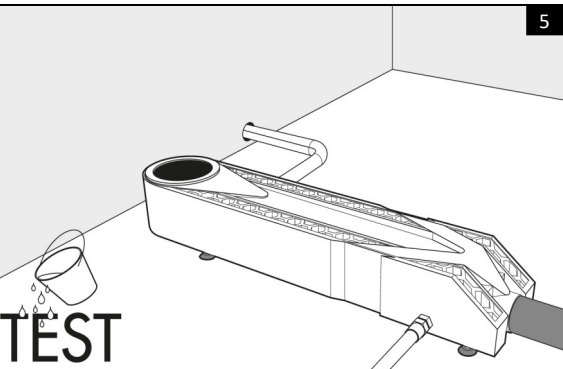
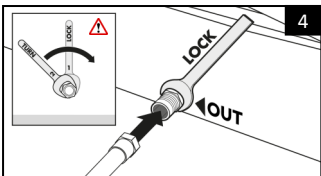
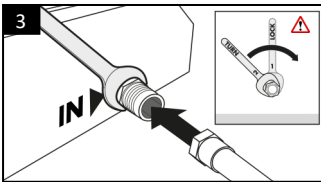
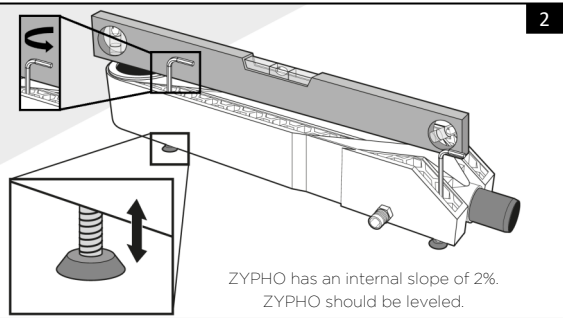
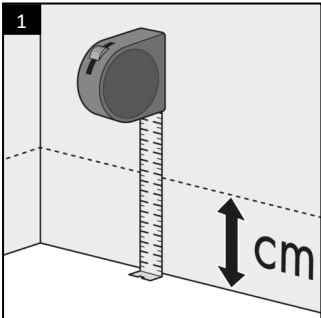
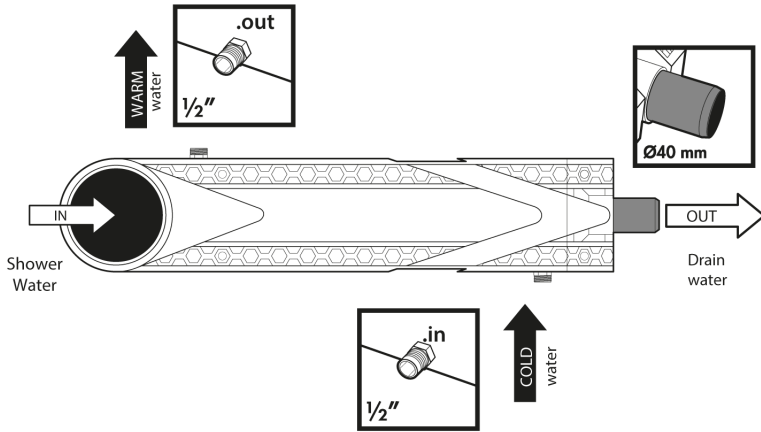

INSTALLATION CONFIGURATION

Choose configuration A, B or C

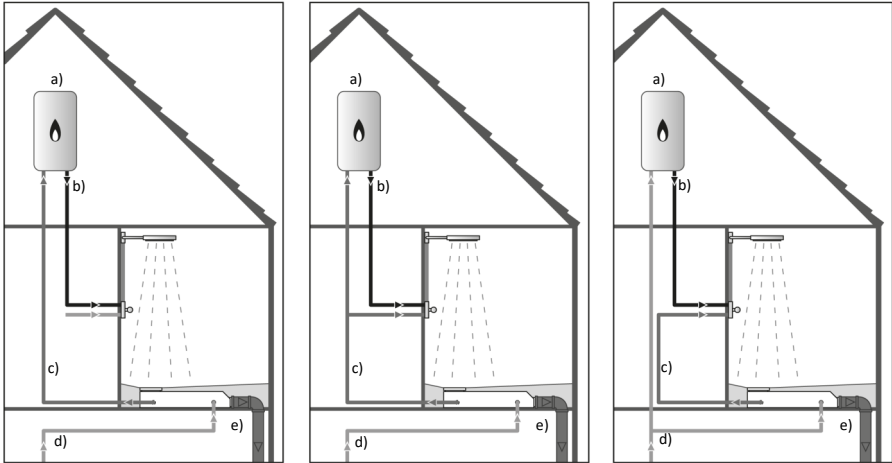

a) water heater b) hot water pipe c) warm water pipe d) cold water pipe e) drain pipe

TECHNICAL SPECIFICATIONS

	Unit	Value
Temperature range	°C	0 - 60
Maximum mains water pressure	bar	6
Pressure drop with mains water at 9.2L / min	bar	0.3
Maximum shower flow	l/min	30
Heat exchanger material	-	Copper
ZYPHO body material	-	ABS
Net weight	kg	5.5

PACKAGE CONTENTS

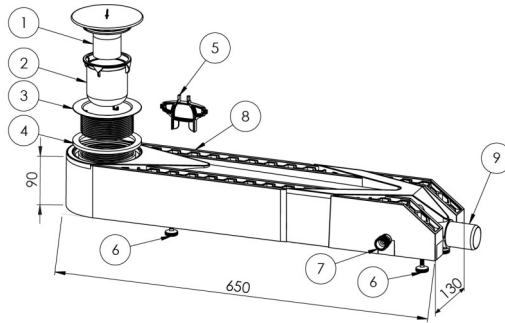

Nº	Description	Material	Connection	Qty
1	Valve cap Ø90 mm	ABS	-	1
2	Trap	ABS	-	1
3	Thread ring	PP	-	1
4	Sealing ring	Rubber	-	1
5	Wrench	PP	-	1
6	Adjustable foot	Steel/Plastic	-	4
7	Input connector 1/2"	Gunmetal	M	1
8	Output connector 1/2"	Gunmetal	M	1
9	Water discharge Ø40 mm	PVC	M	1

DIMENSIONS

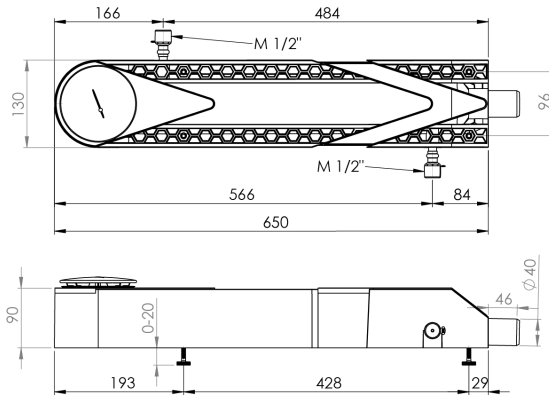

SAFETY

Tested Product

ZYPHO heat exchanger is double walled according to European regulations EN 1717 ("Protection against pollution of potable water in water installations and general requirements of devices to prevent pollution by backflow"). Complementary to (preventive) quality control during production process, we carry out test in all ZYPHO units in our factory before packaging and shipping. Tests are done to the copper main water circuit and connections by pressurizing it up to 7 bar and to the drain water circuit and sealing points up to 1 bar to ensure that there are no leaks or defects

Legionella Prevention

ZYPHO's design allows to minimize Legionella-related risks:

- The unit has no dead spaces and is subject to high flow rates which prevents water from stagnation.
- Drain water never stays a long time inside of the unit since its construction guarantees that it is fully drained out at the end of the shower.
- After shower, fresh water cools down below 25°C, as recommended by the WHO and the European Working Group for Legionella Infections.
- The ZYPHO is always installed relatively close to the shower mixer which minimizes the distance between the unit and the shower valve.
- Copper coil itself contributes to reducing Legionella-related risks.

MAINTENANCE

ZYPHO Standard must be installed with a shower drain filter and trap to prevent the passage of debris. Like any other drain pipe, we recommend a periodically cleaning. Use a non-corrosive drain cleaner and ZYPHO's cleaning brush or other flexible drain brush that easily goes through the ZYPHO pushing the debris towards the sewer. See ZYPHO's Standard accessories section on our website (www.ZYPHO.eu) for our recommendation for the ZYPHO brush.

WARRANTY — 10 YEARS

During the warranty period, EIDT, SA or an authorized company will replace or repair any Product that has a defect in design, material or workmanship provided the Product is returned, packaging and transportation charges prepaid, to Manufacturer with Manufacturer's prior permission (unless otherwise required by law).

Will be excluded from this limited warranty defects caused by:

- Installed water pressure above the limits regulated by law.
- Use of the system without filter and trap.
- Inadequate cleaning of the filter and trap.
- Inadequate installation of the ZYPHO.
- Misuse of the ZYPHO or normal wear of its componentes
- Unauthorized repairs and modifications.
- Damage due to an accident, incl. during transportation, neglect, or any cause other than ordinary use.

The statement of limited warranty is valid in any country where the ZYPHO is distributed and represented. Contacts for additional warranty services and services at the customer premises may be available from any representative or agent of ZYPHO in countries where it is distributed.

CONTACTS

PRODUCT DEVELOPED BY EIDT, SA

EN5, Z.I. Comercio Industria, Armazém 29. 2870-500, Montijo

Portugal

+351 210 991 351

b2b@zypho.eu

www.zypho.eu

PATENTED (PCT054506)

Z8DWPT-V01-1017-EN